

ICE-O-MATIC®

A **WELBILT** Company

Use and Care Guide AUTOMATIC ICE MAKER

Parts and features

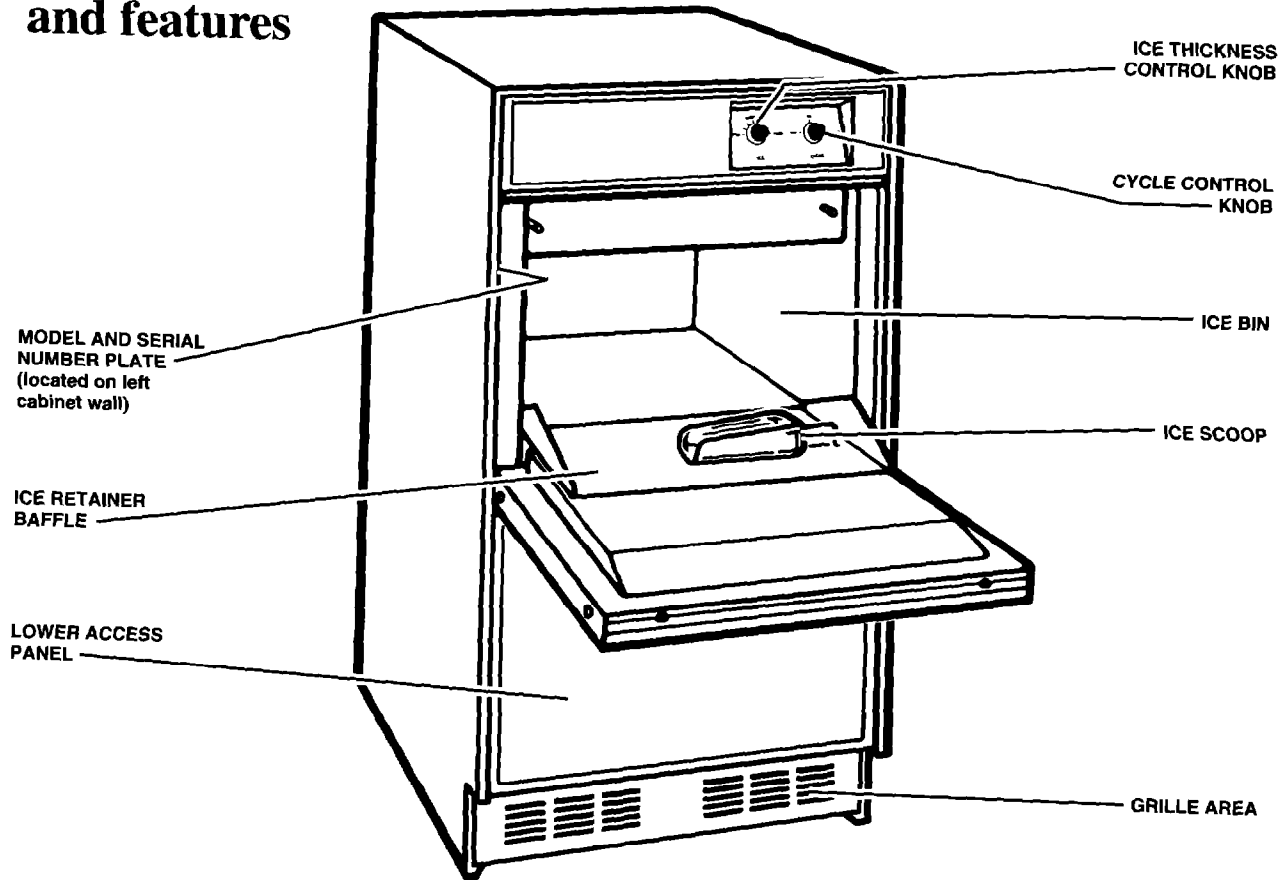

Copy your Model and Serial Numbers here ...

When you need service, or call with a question, have this information ready:

1. Complete Model and Serial Numbers (from the plate located as shown).

2. Purchase date from sales slip.

Copy this information in these spaces. Keep this book, your warranty, and sales slip together in a handy place.

Model Number _____

Serial Number _____

Purchase Date _____

Service Company and Telephone Number _____

PART NO. 2180626 Rev. A

5-97

Contents

	Page		Page
ICE MAKER SAFETY	2-3	Cleaning the Condenser	7
USING YOUR ICE MAKER	4	Cleaning the Ice Maker System	8
How the Ice Maker Works	4	Cleaning the Interior Components	9
Setting the Controls	4	Filtering and Treating Water	10
Changing the Bin Door Panel	5	VACATION AND MOVING CARE	10
Changing the Lower Access Panel	6	IF YOU NEED SERVICE OR ASSISTANCE	11
CLEANING AND CARING FOR		Before Calling for Service	11
YOUR ICE MAKER	7	WARRANTY	12
Cleaning Exterior Surfaces	7		

Ice Maker Safety

Your safety and the safety of others is very important.

We have provided many important safety messages in this manual and on your appliance. Always read and obey all safety messages.



This is the safety alert symbol.

This symbol alerts you to hazards that can kill or hurt you and others.

All safety messages will be preceded by the safety alert symbol and the word "DANGER" or "WARNING." These words mean:

⚠ DANGER

You will be killed or seriously injured if you don't follow instructions.

⚠ WARNING

You can be killed or seriously injured if you don't follow instructions.

All safety messages will identify the hazard, tell you how to reduce the chance of injury, and tell you what can happen if the instructions are not followed.

IMPORTANT SAFETY INSTRUCTIONS

WARNING – To reduce the risk of fire, electric shock, or injury when using your ice maker, follow these basic precautions:

- Plug into grounded 3 prong outlet.
- Do not remove ground prong.
- Do not use an adapter.
- Do not use an extension cord.
- Disconnect power before cleaning.
- Disconnect power before servicing.
- Replace all panels before operating.
- Use two or more people to move or install ice maker.

– SAVE THESE INSTRUCTIONS –

It is your responsibility to make sure the ice maker:

- Is installed and properly leveled where it is protected from the elements.
- Is located so that the front is not blocked to restrict airflow.
- Is located in a well ventilated area with temperatures above 55°F (13°C) and below 110°F (43°C). Best results are obtained at temperatures between 70°F (21°C) and 90°F (32°C).
- Is properly connected to a water supply and drain.
- Is properly connected to electricity. A 115 Volt, 60 Hz., AC only, 15 or 20 ampere electrical supply circuit, properly

grounded in accordance with the National Electrical Code and local codes and ordinances, is required.

NOTE: A time delay fuse or circuit breaker is recommended.

- Is not used by anyone unable to operate it properly.
- Is used only to do what ice makers are designed to do.
- Is properly maintained.

ELECTRICAL REQUIREMENTS

A 115 Volt, 60 Hz., AC only, 15 or 20 ampere electrical supply circuit, properly grounded in accordance with the National Electrical Code and local codes and ordinances, is required.

It is recommended that a separate circuit, serving only this appliance, be provided. Use a receptacle which cannot be turned off with a switch or pull chain.

⚠ WARNING



Electrical Shock Hazard

Plug into a grounded 3 prong outlet.

Do not remove ground prong.

Do not use an adapter.

Do not use an extension cord.

Failure to follow these instructions can result in death, fire, or electrical shock.

GROUNDING METHOD

For your personal safety, this appliance must be grounded. This appliance is equipped with a power supply cord having a 3-prong grounding plug. To minimize possible shock hazard, the cord must be plugged into a mating, 3-prong, grounding-type wall receptacle, grounded in accordance with the National Electrical Code and local codes and ordinances. If a mating wall receptacle is not available, it is the personal responsibility of the customer to have a properly grounded, 3-prong wall receptacle installed by a qualified electrician.

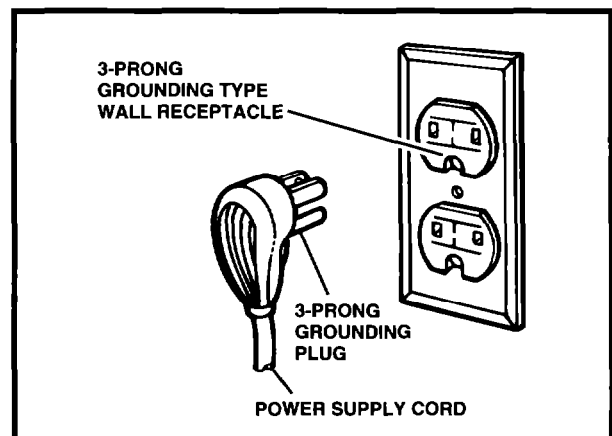

Using your ice maker

How the ice maker works

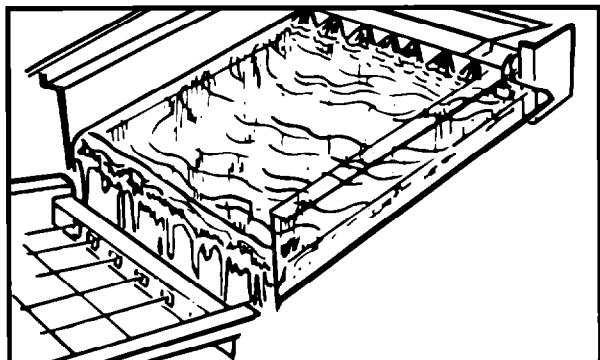

1. Water is constantly circulated over a freezing plate. As the water freezes into ice, the minerals in the water are rejected. This produces a clear sheet of ice with a low mineral content.

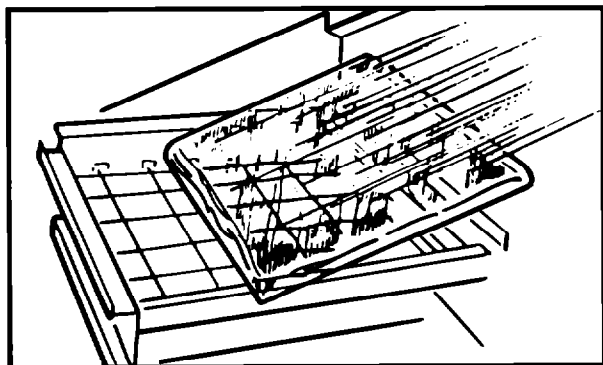

2. When the desired thickness is reached, the ice sheet is released and slides onto a cutter grid. The grid divides the sheet into individual cubes.

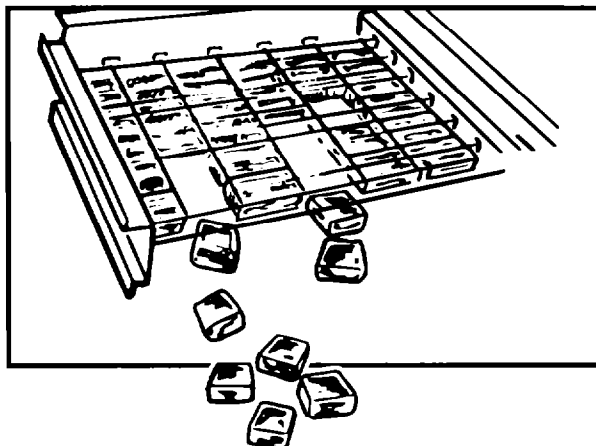

3. The water containing the rejected minerals is drained after each freezing cycle.
4. Fresh water enters the machine for the next freezing cycle.
5. Cubes fall into the storage bin. When the bin is full, the ice maker shuts off automatically and restarts when more ice is needed.

Setting the controls

1. Select an ice thickness. The ice maker has been preset to produce ice approximately $\frac{1}{2}$ " thick while operating in a room temperature of 70°F (21°C).

Operation in different room temperatures may require readjusting the Ice Thickness Control Knob toward "THICK" or "THIN."

Best operation will be obtained with ice $\frac{1}{2}$ " to $\frac{5}{8}$ " thick.

If operating in a warm room temperature (above 90°F (32°C)), do not set Ice Thickness Control Knob to maximum thickness. Doing so could cause the unit to malfunction.

2. To start the normal freezing cycle, turn the Cycle Control Knob to "ON." See Figure A.
3. To stop ice maker operation, turn the Cycle Control Knob to "OFF." See Figure B.

The "CLEAN" setting is used whenever solutions are circulated through the ice maker for cleaning. Only the water pump operates at this setting.

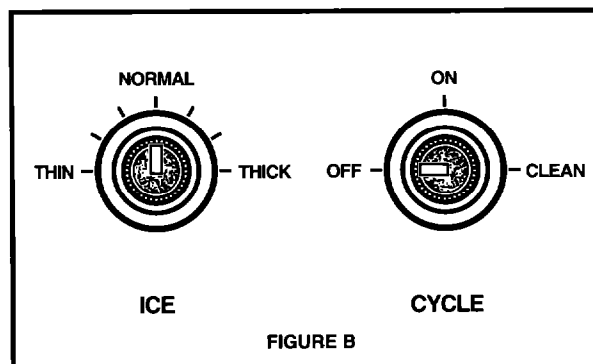
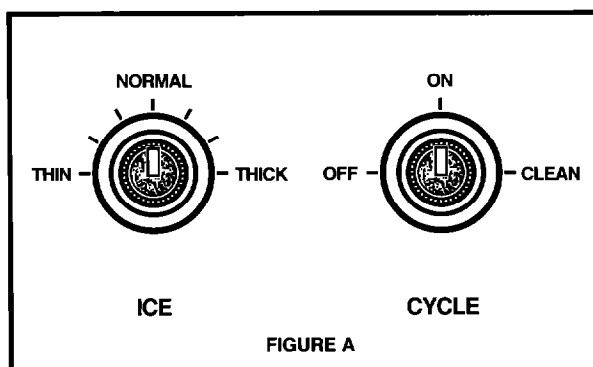

Changing the bin door panel

All models, except those with stainless steel fronts, are equipped with double-sided decorator panels for both the bin door and the lower access panel. The panels are either black/white or almond/harvest gold.

You can also make custom panels to match your existing cabinets.

To change the bin door panel (Style 1):

1. Open the storage bin door and remove the 2 screws on top of the door. These screws hold the handle in place.
2. Loosen the screws in both side trim pieces.
3. Remove the handle and the handle insert. Proceed to step 4.

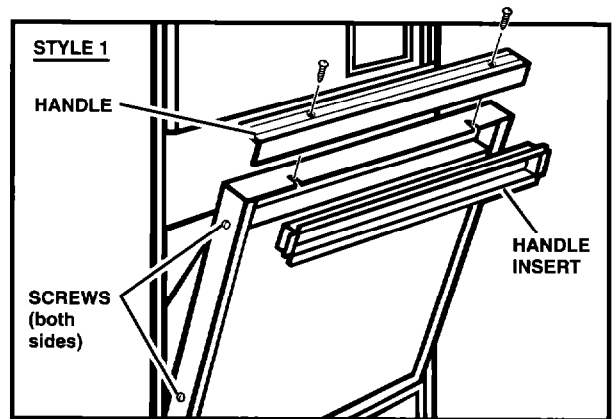

To change the bin door panel (Style 2):

1. Open the storage bin door and remove the 2 screws on top of the door. These screws hold the handle in place.
2. Loosen the screws in both side trim pieces.
3. Remove the handle.

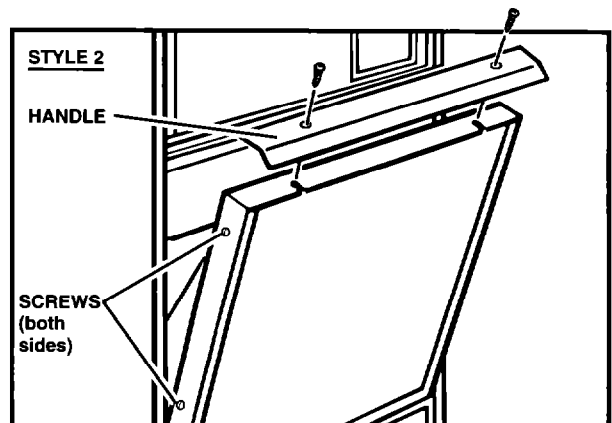

4. Carefully slide out the decorator panel and reassemble with the selected surface facing out. Be careful not to scratch the panel as it is inserted. See figure in right column.

NOTE: To use a custom panel, remove the decorator panel, and the styrofoam door insulation. Break off all of the ribs on the door insulation. This step is needed to allow for the custom panel thickness. The custom panel should be $\frac{1}{4}$ " (6 mm) thick.

- **For door Style 1:** The custom panel should be 17" wide x 11-14 $\frac{1}{4}$ " tall (433 mm x 286 mm).
- **For door Style 2:** The custom panel should be 17" wide x 13 $\frac{3}{16}$ " tall (433 mm x 335 mm).

Reinstall the modified door insulation in the door assembly, and slide the custom panel between the front trims and the insulation. Be careful not to scratch the custom panel as it is inserted.

5. Replace the handle, handle insert (on some models), and screws. Tighten the handle and side trim screws.

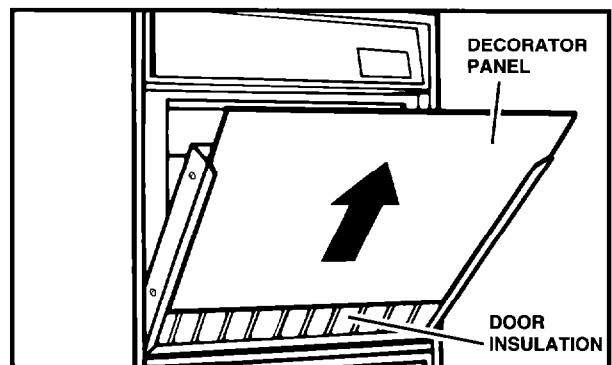

Changing the lower access panel



⚠ WARNING

Electrical Shock Hazard

Disconnect power before servicing.
Replace all panels before operating.
Failure to do so can result in death or electrical shock.

1. Unplug ice maker or disconnect power.

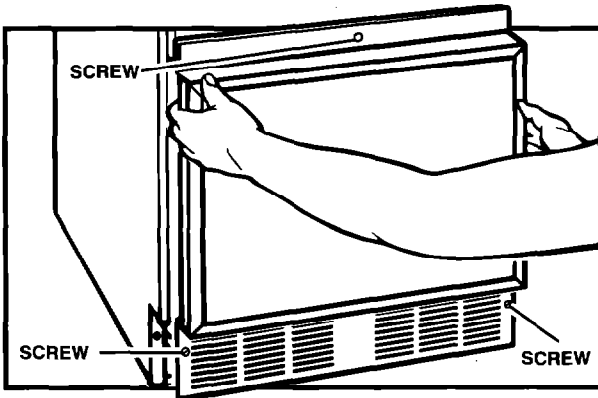

2. Remove the 2 screws in the lower access panel and the 1 screw from the center of the front panel support. (Open the door slightly for better access to the screw.) Pull the bottom forward and then pull down to remove the lower access panel.

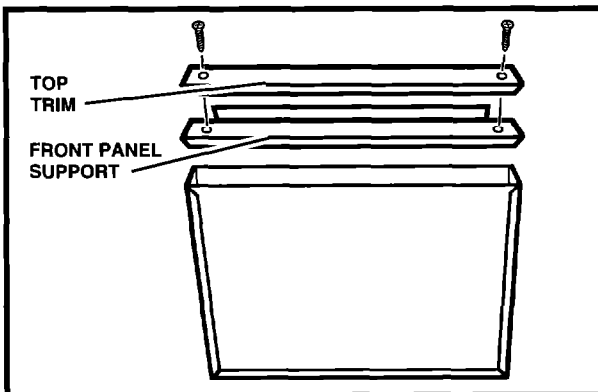

3. Remove the 2 screws from the top panel trim and remove the top trim.

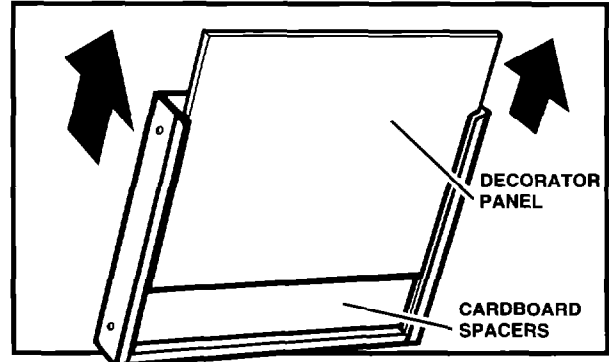

4. Carefully slide out the decorator panel and reassemble with the selected surface out. Be careful not to scratch the panel as it is inserted. See figure above.

NOTE: To use a custom panel, remove the decorator panel and both of the cardboard spacers. This step is needed to allow for the custom panel thickness. The custom panel should be $\frac{1}{4}$ " (6 mm) thick and 17" wide x $11\frac{15}{16}$ " tall (433 mm x 303 mm). Slide the custom panel between the front trims and the rear panel of the lower panel assembly. Be careful not to scratch the custom panel as it is inserted.

5. Replace the top trim and screws.
6. Reinstall the lower access panel assembly and screws.
7. Plug in ice maker or reconnect power.

Cleaning and caring for your ice maker

Periodically inspect and clean the ice maker to keep it operating at peak efficiency and to prevent premature failure of system components.

Both the ice making system and the air-cooled condenser need to be cleaned regularly.

The minerals rejected from the circulating water during the freezing cycle will eventually form a hard, scaly deposit in the water system which prevents a rapid release of the ice from the freezing plate.

Clean the ice and water systems periodically to remove mineral scale buildup. Frequency of cleaning depends on water hardness. With water that contains few impurities, cleaning may not be required for several years. With hard water (15 to 20 grains/gallon), cleaning may be required as frequently as every 6 months.

Cleaning exterior surfaces

Wash the exterior painted surfaces and gaskets with warm water and mild soap or detergent. Wipe and dry. Regular use of a good household appliance cleaner and wax will help protect the finish.

Do not use harsh or abrasive cleaners on the enamel surfaces. They may scratch the finish.

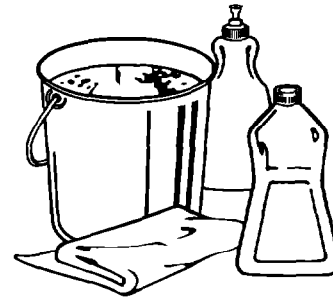

Cleaning the condenser

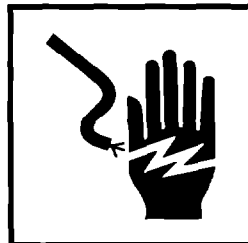

⚠ WARNING

Electrical Shock Hazard

**Disconnect power before cleaning.
Replace all panels before operating.
Failure to do so can result in death or electrical shock.**

A dirty or clogged condenser:

- Prevents proper airflow.
- Reduces ice making capacity.
- Causes higher than recommended operating temperatures which may lead to component failure.

1. Unplug ice maker or disconnect power.

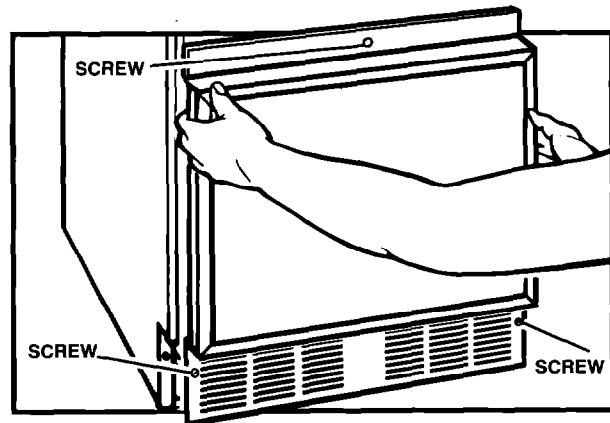

2. Remove the 2 screws in the lower access panel and the 1 screw from the center of the front panel support. (Open bin door slightly for better access to screw.)
3. Pull the bottom forward and then pull down to remove the lower access panel.

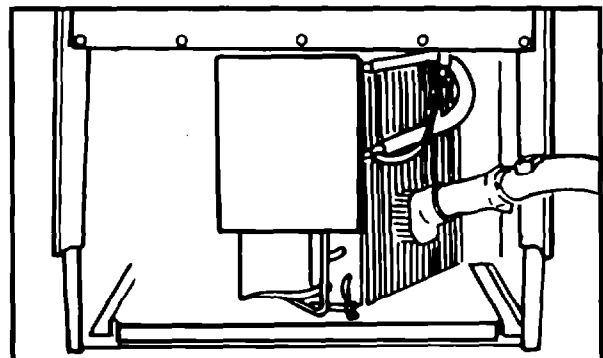

4. Remove dirt and lint from the condenser fins and the unit compartment with a brush attachment connected to a vacuum cleaner. Condenser fins can bend easily. Use care when vacuuming the condenser to keep from bending fins.
5. Replace the grilled front panel and screws.
6. Plug in ice maker or reconnect power.

Cleaning the ice maker system

1. Place the Cycle Control Knob in the "OFF" position.

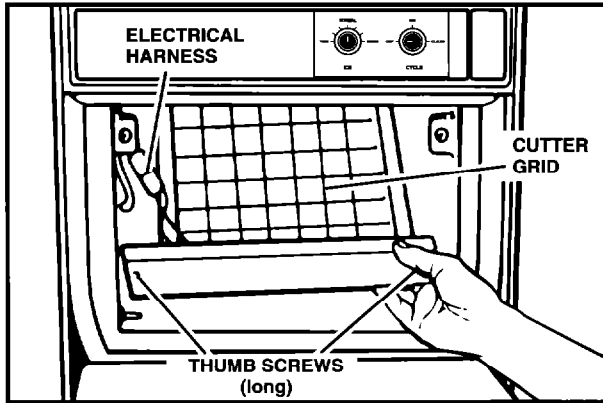

2. Remove the 2 thumb screws, and slide the ice cutter grid forward, out of the 2 slots near the water pan. Any ice on the grid should be melted under running warm water. Attempting to pick the ice slab from the grid may stretch and damage the grid wires.
3. Unplug the electrical harness.
4. Remove all ice from the storage bin and the freezing plate.

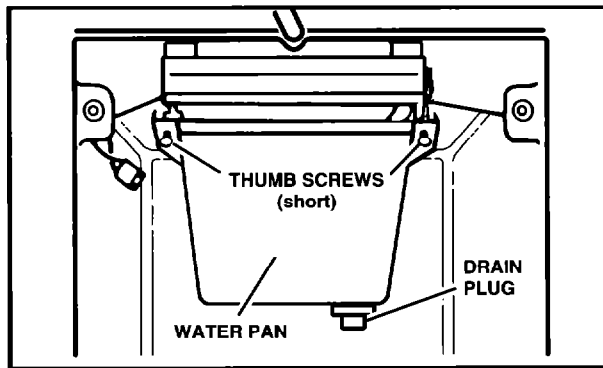

5. Drain the water pan by removing the drain plug. When finished, replace the drain plug.

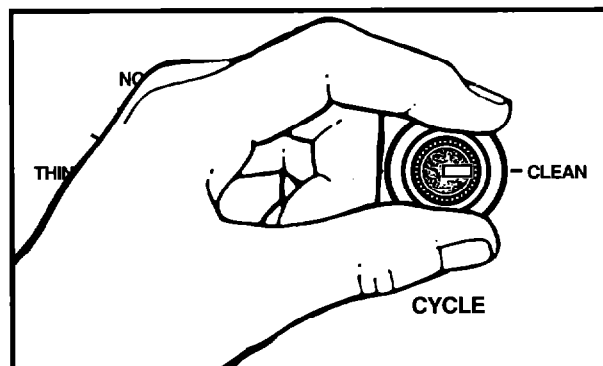

6. Pour 2 quarts (2 L) of hot water into the water pan and turn the Cycle Control Knob to "CLEAN." This step warms up the system and allows the cleaning solution to be more effective. Allow to circulate 5 minutes. Turn the Cycle Control Knob to "OFF" and drain. Prepare the cleaning solution by thoroughly mixing 6 oz. (170 g) of powdered citric acid or phosphoric acid into 2 quarts (2 L) of hot water.

Commercial ice machine cleaners are also available in liquid form and should be mixed according to instructions on the label.

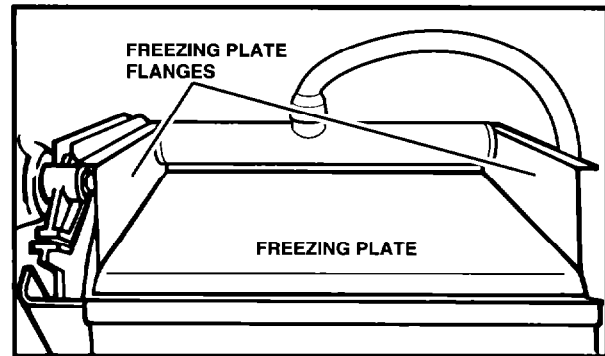

7. Pour cleaning solution into water pan and turn the Cycle Control Knob to "CLEAN." If solution foams while pouring, stop until foaming subsides, then add balance of solution. Allow solution to circulate until scale has dissolved. The circulating solution may not contact scale on the side flanges of the freezing plate. To remove this scale, wear rubber gloves and use a stainless steel sponge or pad dipped in cleaning solution to scrub the side flanges until scale is removed. Generally scale will be dissolved in 15 to 30 minutes. Severe scale formation may require repeating the cleaning process with a fresh quantity of solution if the scale has not dissolved after 30 minutes.
8. Turn the Cycle Control Knob to "OFF" and drain.
9. Follow cleaning with 2 fresh water rinses, circulating each rinse for 5 minutes, and drain.
10. This completes the "in place" cleaning and sanitizing of the water system and freezing plate. Other interior components must also be cleaned and sanitized.

Cleaning the interior components



⚠ WARNING

Electrical Shock Hazard

Disconnect power before cleaning.
Replace all panels before operating.
Failure to do so can result in death or electrical shock.

1. Unplug ice maker or disconnect power.
2. Open the storage bin door and remove any ice that is in the bin.

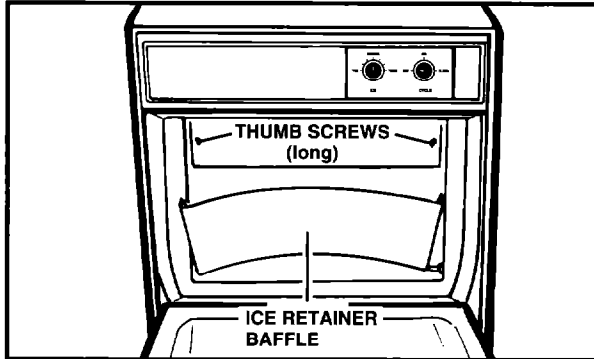

3. Remove the ice retainer baffle by flexing it and sliding it off the studs.
4. Remove the ice cutter grid by unscrewing the 2 thumb screws, sliding the grid forward, and unplugging the electrical wire harness.

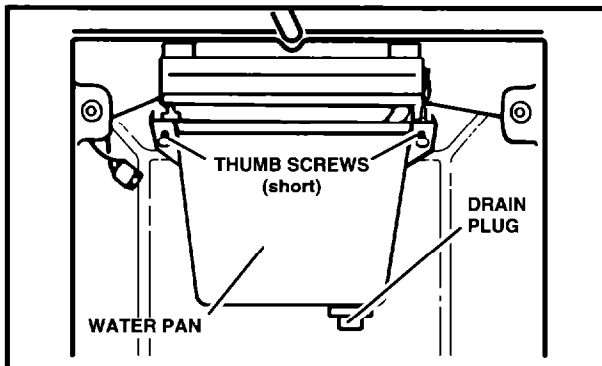

5. Remove the water pan by unscrewing the 2 thumb screws.

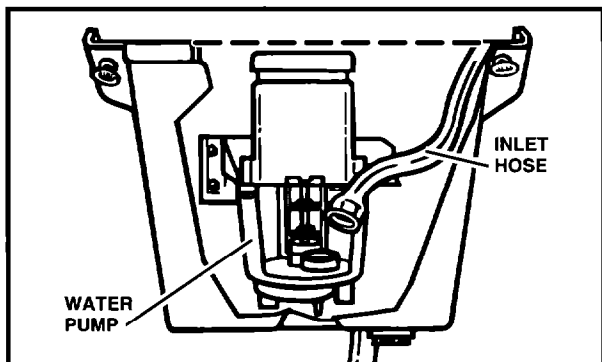

6. Remove the hose from the water pump.

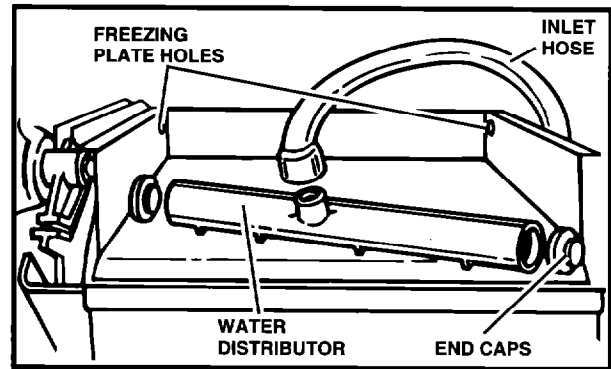

7. Remove the water distributor from the freezing plate. It is held in place by rubber end caps. Remove the inlet hose and clean all water distributor holes and the small orifice in the inlet side of the water distributor. When replacing the water distributor, make sure the end caps are located in the freezing plate holes and that the water distributor holes face down.
8. Wash the **interior components** (ice retainer baffle, cutter grid, water pan, inlet hose, and water distributor) and the storage bin, door gasket, and ice scoop with mild soap or detergent and warm water. Rinse in clean water. The components should also be cleaned in a solution of 1 tablespoon (15 mL) of household bleach mixed with 1 gallon (3.8 L) warm water.
DO NOT WASH PLASTIC PARTS IN THE DISHWASHER. They cannot withstand temperatures above 145°F (63°C).
9. Replace the interior components (water distributor, inlet hose, water pan, cutter grid, and ice retainer baffle).
10. Check the following:
 - Hose from water valve is in the water pan.
 - Rubber drain plug is in the water pan.
 - Water distributor is seated and holes are facing down.
 - Hose is connected to the pump and the water distributor.
 - Hose from water pan is inserted into the storage bin drain opening.
11. Reconnect the electrical harness, and slide cutter grid into place. Tighten the thumb screws.
12. Plug in ice maker or reconnect power.
13. Reset the controls, see "Setting the controls" on page 4.

Filtering and treating water

In some areas, it may be beneficial to filter or treat the water being supplied to the ice maker. It can improve the reliability of the machine, reduce water system maintenance, and produce a better quality of ice.

The installation of a polyphosphate feeder will generally reduce scale buildup, and the ice maker will require less frequent cleaning.

For information about filtering and treating the water, see the dealer from whom you purchased your ice maker.

Vacation and moving care



!WARNING

Electrical Shock Hazard

Disconnect power before servicing.
Replace all panels before operating.
Failure to do so can result in death or electrical shock.

To shut down the ice maker:

1. Unplug ice maker or disconnect power.
2. Remove all ice from the storage bin.
3. Shut off the water supply.

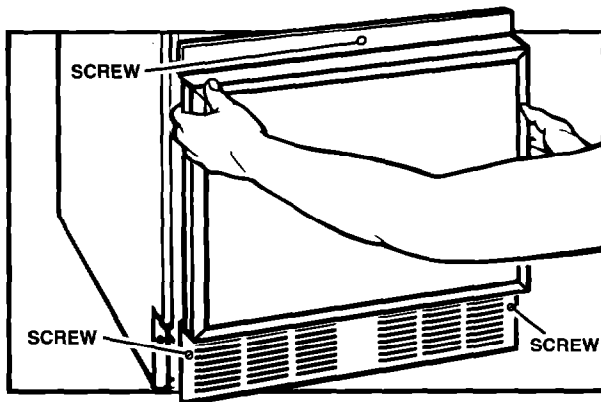

4. Remove the 2 screws in the lower grille area and the 1 screw from the center of the front panel support. (Open bin door slightly for better access to screw.) Pull the bottom forward and down then pull to remove the lower access panel.

5. Disconnect the inlet and outlet hoses to the water valve. Allow these hoses to drain, then reconnect them to the valve.
6. Replace the lower access panel and screws.

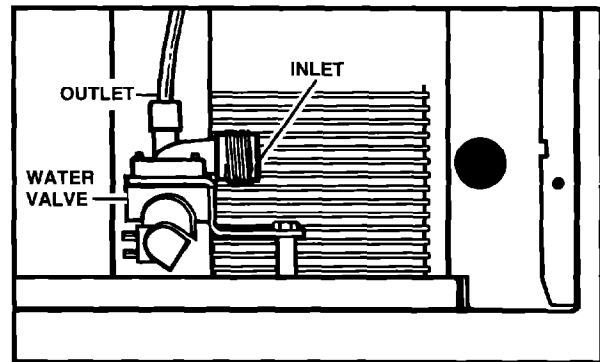

7. Drain water from water pan by removing drain plug. Also, remove water from drain line.
8. Before using the machine again, clean the ice maker system, interior components, and the storage bin.

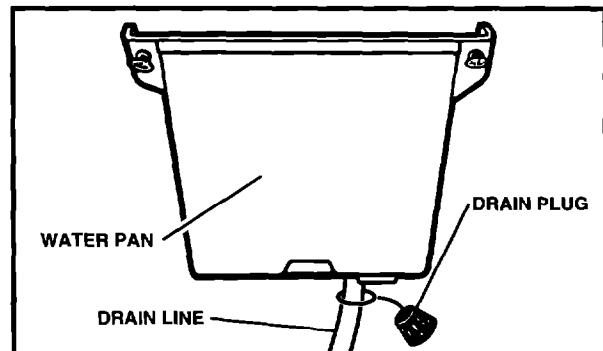

9. Plug in ice maker or reconnect power.

NOTE: All components of the ice maker are permanently lubricated at the factory. They should not require any additional oiling throughout the normal life of the machine.

If you need service or assistance, we suggest you follow these steps:

Before calling for service ...

Performance problems often result from little things you can find and fix yourself, without tools of any kind.

Unit does not run:

- Cycle Control Knob must be in the "ON" position.
- Check to see that the power cord is plugged in.
- Check for a blown fuse or tripped circuit breaker in the electrical supply to the machine.
- Room temperatures must be above 55°F (13°C). Otherwise, the Bin Thermostat may sense a cold room temperature and shut off even though the storage bin is not full of ice. Also, the unit may not restart once it does shut off.

Unit runs but does not produce ice:

- Cycle Control Knob must be in the "ON" position.
- Check water supply to make sure it is open.
- If ice maker is to be operated at an elevation of 2,000 feet (600 m) or more above sea level, both the Bin Thermostat and the Ice Thickness Thermostat will need to be recalibrated. Call your dealer or an authorized service group to have the necessary changes made.

Unit runs but produces very little ice:

- Room temperature may be extremely high (over 90°F (32°C)). In this case, it is normal for ice production to be low.
- Dirt or lint may be blocking the air flow through the finned condenser. Condenser needs to be cleaned.
- Check to see if the unit has a scale buildup in the water and/or freezing systems. Clean them, if necessary.

Grid is not cutting ice sheets:

- Check the grid harness plug to make sure the connection is secure.

Off taste in ice cubes:

- There may be an unusually high mineral content in the water supply. Water may need to be filtered or treated.
- Do not store any foods in the ice bin.
- Packaging materials are not all removed.

Service repair and replacement parts manuals may be ordered directly from:

Mile High Equipment Company
11100 E. 45th Avenue
Denver, Colorado 80239
(303) 371-3737

Specify the model and serial number of the ice maker when ordering.

EUC050

LIMITED ONE YEAR PARTS WARRANTY

ICE-O-MATIC®
A **WELBILT** Company

MILE HIGH EQUIPMENT COMPANY 11100 East 45th Avenue, Denver, CO 80239 Phone (303) 371-3737 TWX 910-932-0317

To the original owner of an ICE-O-MATIC ICE MAKER.

We warrant every Ice-O-Matic Ice Machine to be free from defects in material and factory workmanship if properly installed, cared for and operated under normal conditions with competent supervision. WITHIN ONE YEAR FROM DATE OF ORIGINAL INSTALLATION WHEN REPORTED ON A WARRANTY CARD RETURNED TO THE FACTORY we will replace, F.O.B. our plant, Denver, CO, or F.O.B. authorized Mile High Equipment Co. Parts Depots, without cost to the customer, that part of any such machine that becomes defective, BUT no part or assembly which has been subject to any alteration or misuse, accident, or is from a machine on which the serial number has been altered or removed. We will also honor warranty for 15 MONTHS from date of shipment whichever period is last to expire, provided in either such case installation of the equipment is reported on warranty card and returned to the factory at the time of installation. After thorough examination, the decision of our Service Department shall be final. Any defective parts to be repaired or replaced must be returned to us, transportation charges prepaid, and they must be properly sealed and tagged. The serial and model number of the machine, and the date of original installation of such machine must be given. We will not, however, assume any responsibility for any expenses (including labor) incurred in the field incidental to the repair or replacement of equipment covered by this warranty. Our obligation hereunder to repair or replace a defective part is the exclusive remedy for breach of this warranty; and we will not be liable for any other damages or claims, including consequential damages.

No representative, dealer, distributor or any other person is authorized or permitted to make any other warranty or obligate MILE HIGH EQUIPMENT COMPANY, to any liability not strictly in accordance with this policy. THIS WARRANTY IS IN LIEU OF ALL OTHER WARRANTIES EXPRESSED OR IMPLIED, INCLUDING ANY WARRANTY OF MERCHANTABILITY, AND OF ALL OTHER OBLIGATIONS OR LIABILITIES ON OUR PART.

This warranty gives you specific legal rights, and you may also have other rights which vary from state to state. Some states do not allow limitations on how long an implied warranty lasts, so the above limitation may not apply to you. Some states do not allow the exclusion or limitation of incidental or consequential damages, so the above limitation or exclusion may not apply to you.